

CABINET UNIT HEATER SUBMITTAL DATA

CBS-RC-15M

Recessed Ceiling Units - Models RC - Metric

PIPING AND MOUNTING CONNECTIONS SHOWN ARE TYPICAL FOR ALL AIR FLOW ARRANGEMENTS SEE OTHER SIDE.

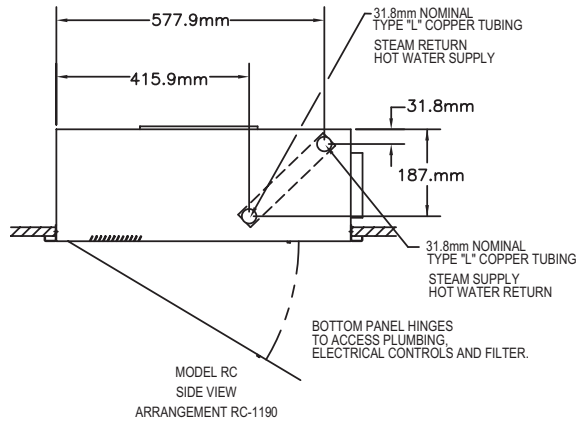

STANDARD ONE ROW COIL
PIPING DIMENSIONS.
(SHOWN ABOVE)

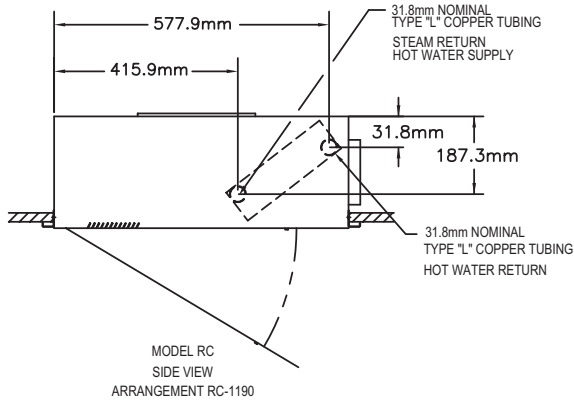
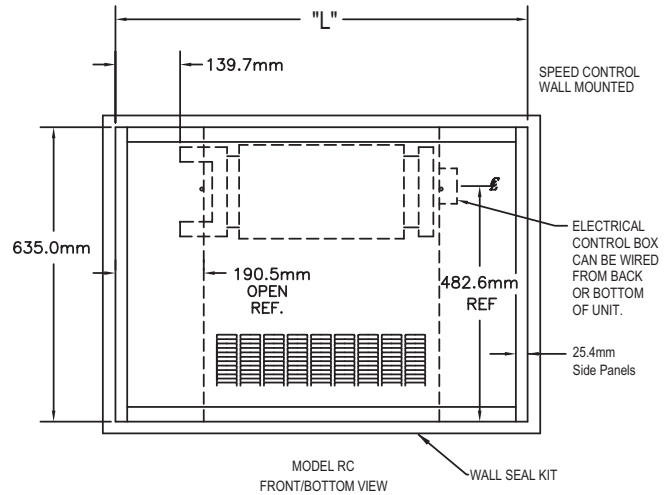
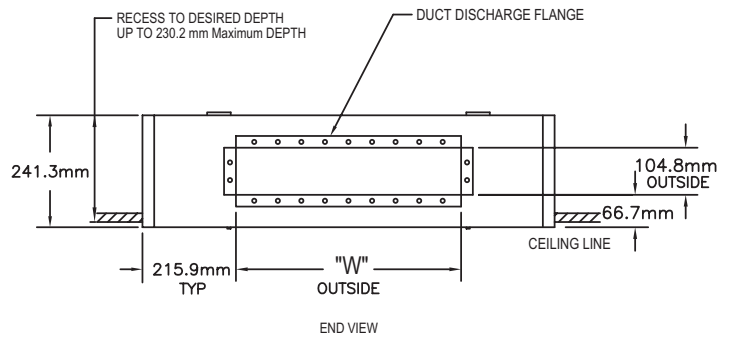

TWO ROW COIL PIPING DIMENSIONS
(SHOWN ABOVE)

SIZE	DIM "L"	DIM "W"
02	889.0mm	460.4mm
03	1092.2mm	663.6mm
04	1193.8mm	765.2mm
06	1498.6mm	1070.0mm
08	1549.4mm	1120.8mm
10	1676.4mm	1247.8mm
12	1854.2mm	1425.6mm
14	2159.0mm	1730.4mm

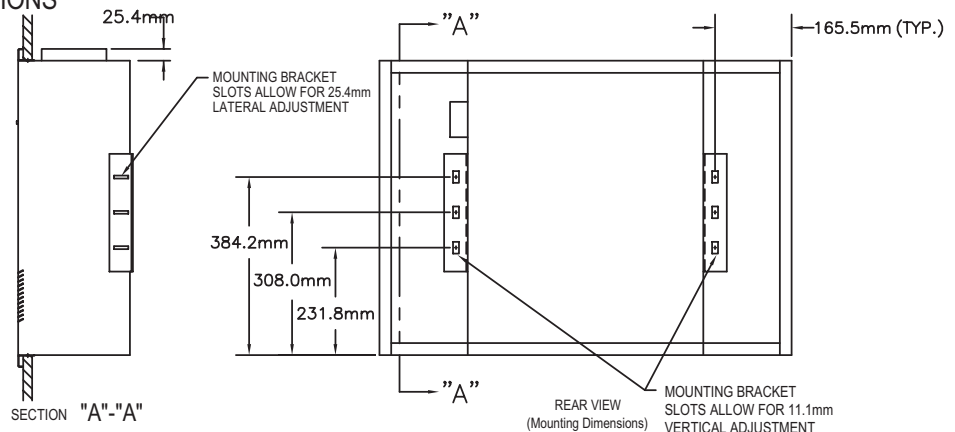

PROJECT: _____
 LOCATION: _____
 ARCHITECT: _____
 ENGINEER: _____
 CONTRACTOR: _____
 PO NUMBER: _____
 DATE: _____

CAT00213B



260 NORTH ELM STREET / WESTFIELD, MA 01085
 TEL: (413) 568-9571 FAX: (413) 562-8437
 www.sterlingheat.com



CABINET UNIT HEATERS RATINGS AND SPECIFICATIONS

ENTERING WATER - 93.3°C
ENTERING AIR - 15.5°C

TABLE I - METRIC

UNIT SIZE		02	03	04	06	08	10	12	14
HEATING CAP. - HOT WATER	WATTS	4806.4	6682.0	8733.5	14067.4	15972.4	18170.4	22156.2	23006.1
	LITER/SECOND	0.10	0.14	0.19	0.30	0.34	0.39	0.48	0.50
HIGH CAP. - COIL 2 ROW	WATTS	7561.2	10374.7	13569.2	20456.4	25673.0	29834.6	35109.9	37688.9
	LITER/SECOND	0.16	0.22	0.29	0.44	0.55	0.64	0.76	0.81
HIGH CAP. - STEAM 2 PSIG	WATTS	6623.4	9202.4	12015.9	19372.0	22009.6	25028.3	30508.7	31710.3
	EDR	94	131	171	275	313	356	434	451
COIL COND. KG/HR		10.6	14.7	19.3	31.0	35.3	40.1	48.9	50.8
	COIL:								
COIL:	NUMBER FINS PER CM	31	31	31	31	31	31	31	31
	FACE AREA-M ²	0.09	0.14	0.17	0.24	0.26	0.29	0.33	0.41
	COIL CONNECTIONS	31.75mm	31.75mm	31.75mm	31.75mm	31.75mm	31.75mm	31.75mm	31.75mm
BLOWERS:	NUMBER	1	1	2	2	3	3	4	4
	DIAMETER(mm)/WIDTH (mm)	146 x 178	146 x 178	146 x 178	146 x 178	146 x 178	146 x 178	146 x 178	146 x 178
STANDARD PSC MOTOR:	DRIVE	DIRECT	DIRECT	DIRECT	DIRECT	DIRECT	DIRECT	DIRECT	DIRECT
	HP	1/15	1/15	1/10	1/10	1 @ 1/10 1 @ 1/15	1 @ 1/10 1 @ 1/15	1/10	1/10
RPM:	HIGH	1050	1050	1050	1050	1050	1050	1050	1050
	LOW	875	875	875	875	875	875	875	875
	NUMBER	1	1	1	1	2	2	2	2
	VOLTS/PHASE/HERTZ	115/1/60	115/1/60	115/1/60	115/1/60	115/1/60	115/1/60	115/1/60	115/1/60
FAN SPEED CONTROL	AMPERES	0.8	0.8	1.4	1.4	2.2	2.2	2.8	2.8
	STANDARD MTR	VAR.	VAR.	VAR.	VAR.	VAR.	VAR.	VAR.	VAR.
CFM:	HIGH	230	335	430	630	860	1060	1230	1410
	LOW	185	270	345	505	685	845	985	1130
	OPTIONAL ECM MOTOR:								
CFM:	HP	1/15	1/15	1/15	1/15	1/10	1/10	1/4	1/4
	NUMBER	1	1	1	1	2	2	2	2
	VOLTS/PHASE/HERTZ	120/1/60	120/1/60	120/1/60	120/1/60	120/1/60	120/1/60	120/1/60	120/1/60
	AMPERES	0.45	0.45	0.65	0.85	1.5	1.95	2.8	2.8
FAN SPEED CONTROL	ECM MTR	3 - SPEED	3 - SPEED	3 - SPEED	3 - SPEED	3 - SPEED	3 - SPEED	3 - SPEED	3 - SPEED
	CFM:								
CFM:	HIGH	230	335	430	630	860	1060	1230	1410
	MED	160	240	375	440	590	740	850	980
	LOW	120	150	280	320	450	560	640	730
FILTERS:	NO.	1	1	1	1	1	1	1	1
	TYPE	PERM.	PERM.	PERM.	PERM.	PERM.	PERM.	PERM.	PERM.
	LENGTH (mm)	501.65	704.85	806.45	1111.25	1162.05	1289.05	1466.85	1771.65
	WIDTH (mm)	220.66	220.66	220.66	220.66	220.66	220.66	220.66	220.66
	THICKNESS (mm)	12.70	12.70	12.70	12.70	12.70	12.70	12.70	12.70
dB. LEVEL 457 (mm) FROM UNIT		50	52	53	54	55	55	56	56
	LENGTH (mm)	889	1092.2	1193.8	1498.6	1549.4	1676.4	1854.2	2159
	HEIGHT (mm)	635	635	635	635	635	635	635	635
	DEPTH (mm)	241.3	241.3	241.3	241.3	241.3	241.3	241.3	241.3

Note: On FS and FSI units use 724 mm on all heights

FILTER IDENTIFICATION AND DATA		
SIZE	PART NO.	FILTER SIZE
02	PC1297-2	11.9mm x 220.7mm x 507.7mm
03	PC1297-3	11.9mm x 220.7mm x 704.9mm
04	PC1297-4	11.9mm x 220.7mm x 806.5mm
06	PC1297-6	11.9mm x 220.7mm x 1111.3mm
08	PC1297-8	11.9mm x 220.7mm x 1162.1mm
10	PC1297-10	11.9mm x 220.7mm x 1289.1mm
12	PC1297-12	11.9mm x 220.7mm x 1466.9mm
14	PC1297-14	11.9mm x 220.7mm x 1771.7mm

CABINET UNIT HEATERS

SHIPPING WEIGHT
(KG)

STYLE	SIZE							
	02	03	04	06	08	10	12	14
RC	46.27	54.89	61.24	74.39	83.01	88.00	97.52	110.22

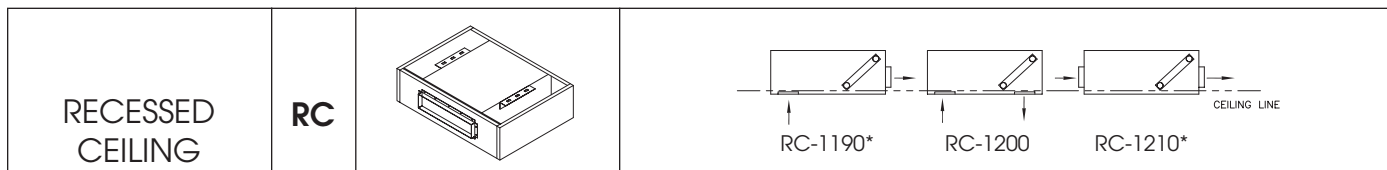

*Arrangement is specifically designed for duct use.

CABINET UNIT HEATERS HEATING CAPACITIES

TABLE II — STANDARD COIL - METRIC

ENTERING WATER - 93.3°C
ENTERING AIR - 15.5°C

UNIT SIZE	LITERS/SECOND	WATER P.D./M	HIGH FAN SPEED				LOW FAN SPEED			
			L/SEC.	WATTS	WTD °C	FAT °C	L/SEC.	WATTS	WTD °C	FAT °C
02	0.032	0.006	108.55	3751.3	28.4	43.9	87.31	3458.2	26.2	48.3
	0.063	0.018		4425.4	16.7	48.9		4044.4	15.3	53.9
	0.095	0.046		4747.8	12.0	51.7		4396.1	11.1	57.2
	0.126	0.073		5099.4	9.6	54.4		4718.4	8.9	60.0
	0.158	0.110		5509.7	8.3	57.2		5070.1	7.6	63.3
03	0.063	0.021	158.10	6242.4	23.6	47.8	127.43	5597.7	21.2	51.7
	0.095	0.049		6447.6	14.7	48.9		5802.8	14.6	53.3
	0.126	0.079		6652.7	12.6	50.0		5890.7	11.1	53.9
	0.158	0.119		6887.2	10.4	51.7		6066.6	9.2	55.0
	0.189	0.168		6975.1	8.7	52.2		6183.8	7.8	55.6
04	0.063	0.021	202.94	6388.9	24.2	41.1	162.82	5568.4	21.1	43.9
	0.126	0.082		7795.7	14.7	47.2		7004.4	13.2	51.1
	0.158	0.125		8499.1	12.9	50.0		7561.2	11.4	53.9
	0.252	0.305		9055.9	8.5	52.2		8030.1	7.6	56.1
	0.315	0.442		9466.2	7.1	53.9		8293.9	6.2	57.8
06	0.126	0.091	297.33	11,840.1	22.4	48.3	238.33	10,462.6	19.8	51.7
	0.189	0.192		13,129.6	16.5	51.7		11,664.2	14.7	56.1
	0.252	0.335		13,833.0	13.1	53.9		12,279.7	11.6	57.8
	0.315	0.488		14,477.7	11.0	55.6		12,777.9	9.7	60.0
	0.379	0.686		14,858.7	9.4	56.7		13,071.0	8.3	61.1
08	0.126	0.094	405.87	13,803.6	26.1	43.3	323.28	12,309.0	23.3	47.2
	0.189	0.195		15,298.3	19.3	46.1		13,627.8	17.2	50.6
	0.252	0.335		15,796.5	14.9	47.2		14,155.3	13.4	51.7
	0.379	0.686		16,412.0	10.3	48.9		14,389.8	9.1	52.2
	0.505	1.173		16,939.5	8.0	50.0		15,005.2	7.1	53.9
10	0.189	0.198	500.26	16,353.4	18.1	42.8	398.80	14,712.2	18.6	46.1
	0.252	0.351		17,701.5	16.7	44.4		15,679.3	14.9	47.8
	0.379	0.716		18,229.0	11.5	45.6		16,031.0	10.1	48.9
	0.505	1.219		18,785.9	8.9	46.7		16,499.9	7.8	49.4
	0.631	1.829		19,342.7	7.3	47.2		17,261.9	6.5	51.1
12	0.252	0.366	580.50	20,954.6	19.8	45.0	464.87	19,078.9	18.1	55.0
	0.379	0.762		21,833.8	13.7	46.7		19,518.5	12.3	56.1
	0.505	1.280		22,478.6	10.6	47.2		19,928.8	9.4	56.7
	0.631	1.920		22,771.6	8.6	47.8		20,221.9	7.6	57.2
	0.757	2.697		23,035.4	7.2	48.3		20,427.1	6.4	57.8
14	0.221	0.305	665.45	20,808.1	22.5	41.1	533.30	19,430.6	21.0	45.6
	0.252	0.396		21,716.6	20.5	42.2		20,046.1	19.0	46.7
	0.379	0.823		22,742.3	14.4	43.9		20,485.7	12.9	47.2
	0.631	2.073		23,709.5	9.0	45.0		21,247.7	8.0	48.3
	0.757	2.911		23,943.9	7.5	45.0		21,394.2	6.7	48.9

CABINET UNIT HEATERS HEATING CAPACITIES

TABLE III — HIGH CAPACITY - 2 ROW COIL - METRIC

ENTERING WATER - 93.3°C
ENTERING AIR - 15.5°C

UNIT SIZE	LITERS/SECOND	WATER P.D./M	HIGH FAN SPEED				LOW FAN SPEED			
			L/SEC.	WATTS	WTD °C	FAT °C	L/SEC.	WATTS	WTD °C	FAT °C
02	0.032	0.009	106.19	5246.0	39.7	56.1	84.95	4835.7	36.6	62.2
	0.063	0.027		6359.6	24.1	65.0		5832.1	22.1	72.2
	0.095	0.067		6828.6	17.2	68.3		6271.7	15.8	76.7
	0.126	0.104		7268.2	13.7	72.2		6594.1	12.5	79.4
	0.158	0.152		7531.9	11.4	73.9		6887.2	10.4	82.2
03	0.063	0.030	155.74	8821.4	33.4	62.2	125.07	8293.9	31.4	70.0
	0.095	0.076		9349.0	23.6	65.0		8469.8	21.4	71.7
	0.126	0.116		9700.7	18.4	66.7		8704.2	16.5	72.8
	0.158	0.171		10,052.3	15.2	68.9		8880.1	13.4	73.9
	0.189	0.235		10,228.2	12.9	69.4		9026.6	11.4	75.0
04	0.063	0.034	198.22	9231.7	35.0	53.9	158.10	8645.6	32.7	60.6
	0.126	0.134		11,576.3	21.9	63.9		10,491.9	32.7	70.0
	0.158	0.180		12,426.2	18.8	67.2		11,078.1	19.9	73.3
	0.252	0.430		13,305.4	12.6	71.1		11,634.9	16.7	76.1
	0.315	0.622		13,715.7	10.4	72.8		11,957.3	11.0	77.8
06	0.126	0.137	292.61	16,880.9	32.0	63.3	233.61	15,444.8	9.0	70.0
	0.189	0.283		18,492.8	23.4	67.8		16,705.1	29.2	74.4
	0.252	0.488		19,342.7	18.3	70.0		17,496.3	21.1	77.2
	0.315	0.701		20,251.2	15.3	72.8		17,936.0	16.6	78.9
	0.379	1.006		20,368.4	12.9	73.3		18,170.4	13.6	79.4
08	0.126	0.140	398.80	19,665.1	37.2	56.1	318.56	17,027.4	11.5	59.4
	0.189	0.290		22,214.8	28.0	61.7		19,987.4	32.2	67.2
	0.252	0.503		23,240.5	22.0	63.3		20,983.9	25.2	70.0
	0.379	1.021		24,207.7	15.2	65.6		21,511.4	19.9	71.1
	0.505	1.707		25,350.7	12.0	67.8		22,214.8	13.6	72.8
10	0.189	0.305	490.83	24,793.8	31.3	57.2	391.72	22,244.1	10.5	62.2
	0.252	0.533		26,552.2	25.1	60.0		23,797.4	28.1	65.6
	0.379	1.067		27,724.5	17.5	62.2		24,618.0	22.5	67.2
	0.505	1.798		28,896.8	13.7	63.9		25,292.0	15.5	68.9
	0.631	2.697		29,776.0	11.2	65.6		26,054.0	12.0	70.6
12	0.252	0.564	571.06	30,860.4	29.2	60.0	457.79	27,343.5	9.9	65.0
	0.379	1.143		32,706.7	20.6	62.8		29,424.3	25.9	68.3
	0.505	1.920		33,791.1	16.0	64.4		30,127.7	18.6	70.0
	0.631	2.880		34,611.7	13.1	65.6		30,772.5	14.2	71.1
	0.757	4.023		35,109.9	11.1	66.1		31,270.7	11.6	71.7
14	0.252	0.625	653.65	32,179.2	30.5	56.1	523.86	29,365.7	9.9	61.7
	0.315	0.914		33,644.6	25.5	57.8		30,332.9	27.8	63.3
	0.379	1.265		34,670.3	21.9	59.4		31,241.4	23.0	65.0
	0.631	3.185		36,868.3	14.0	62.2		32,648.1	19.7	66.7
	0.757	4.435		37,483.8	11.8	62.8		32,882.6	12.4	67.2

SPECIFICATIONS & WARRANTY*

*STANDARD CABINET UNIT ONLY

The contractor shall furnish and install Sterling Cabinet Unit Heaters as selected to meet or exceed job requirements. The Cabinet Unit Heaters will conform to the items listed below and be certified under CSA guidelines.

CABINETS

All cabinets will be constructed with 18-gauge cold rolled steel, side panels and top. The front panel shall be furnished in 16-gauge cold rolled steel. It will have 1/2", 1-1/2 pound insulation with one side neoprene coated in front of coil. The internal cabinet shall be furnished in 18-gauge galvanized steel. Adequate work area for installation of control valves or electrical equipment shall be provided on both sides of the internal cabinet.

The cabinet shall be provided with a neutral eggshell baked enamel prime coat as standard. (Available if specified) Powder coated baked enamel, color selected from standard.

All cabinets shall be supplied with adjustable rear mounting brackets which will provide adjustment to correct alignment of the unit at installation to non square or out of true walls, joists, studs or surfaces. Adjustable leveling legs (two each base leg) are available when specified.

RECESSED UNITS

All recessed units shall be supplied with a "Wall Seal" assembly. This assembly shall provide protection to the wall or ceiling construction material. The "Wall Seal" shall be supplied in an eggshell baked enamel prime coat as standard. (When specified) Baked enamel colors may be selected from standard.

CEILING MOUNT OR RECESSED UNITS

All "C" and "RC" units shall be supplied with a hinged front panel. The multiple hinges shall provide full swing through 90°. A safety chain shall be provided as standard to prevent the face panel from swinging fully open accidentally. This chain must be easily detached to allow full access for servicing. Speed control switch will be shipped with wiring diagram for installation where desired.

FILTERS

All filters supplied as standard shall be reusable aluminum media with a 69% arrestance level. Filters shall be slide in type which are locked into position with a cotter pin.

FANS

Fan wheels shall be centrifugal, forward curved, double width of electro galvanized steel. Fan housings shall be of formed galvanized sheet metal.

COILS

STANDARD ONE ROW - The durable mechanically bonded copper/aluminum coil presents the best of today's hydronic heating technology. All element assemblies are submersion tested at factory at 250 PSI and are rated at a working pressure of 300 PSI. All units are designed so that field modifications can be made to reverse the coil position if required.

HIGH CAPACITY COIL - This is a hot water coil designed to provide increased capacity when the required load exceeds that of the standard coil for a given size. Its construction is similar to the standard coil however, there are two rows of tubes. Element assemblies are submersion tested at 250 PSI and are rated at a working pressure of 300 PSI.

MOTORS

Standard PSC motors shall have integral thermal protection and start at 78% of rated voltage. Optional PSC High Static motors will be capable of operating in high static conditions up to 4 inches of water column. All motors shall be factory run-tested and assembled in unit prior to shipping. Optional ECM and high static motors will have a solid state control board and a 3 speed switch. All motors shall be factory run-tested and assembled in unit prior to shipping.

ELECTRICAL

All primary internal wiring shall be done at the factory and every unit shall be factory tested for reliability.

FRESH AIR DAMPERS ON DESIGATED UNITS ONLY

When desired specify either of the following:

1. Where noted 25% Manual Outside Air Dampers shall be provided. A manually operated damper quadrant shall provide from 0% to 25% outside air through the use of a single blade damper.

2. Where noted 25% Motorized Outside Air Dampers shall be provided. A synchronous motor (115/60/1) interlocked with the blower shall automatically open the outside air damper when blower starts. The single blade damper shall be adjustable from 0% to 25% outside air. When the blower stops or there is a loss of power, the damper shall return to the closed position. A damper override switch shall be provided to prevent damper operation when desired.

WARRANTY

The products in this catalog are warranted by Sterling, to be free from defects in material and workmanship for a period of one (1) year from the date of shipment from Sterling's plant. Sterling's liability under this warranty is limited to replacing or repairing at our option, F.O.B. our plant any defective component or assembly returned to our factory prepaid and with proper return authorization document. All repairs or replacements are made subject to factory inspection. In the interest of product improvement, Sterling reserves the right to make changes without notification.



STERLING
COMMERCIAL HYDRONIC PRODUCTS

260 NORTH ELM STREET / WESTFIELD, MA 01085
TEL: (413) 568-9571 FAX: (413) 562-8437
www.sterlingheat.com



A MESTEK COMPANY